



## K0 Structural Bolt Installation

### K0 Structural Bolt Installation

#### AS/NZS 5131 - Structural Steelwork - Fabrication and Erection

Since being released in 2016, AS/NZS 5131 has provided detailed guidance for the installation of structural bolting. It is directly referenced by AS 4100 and is a secondary reference under the National Construction Code (NCC) and its use is therefore compulsory. This guide has been written in accordance with AS/NZS 5131 and AS 4100 and is intended to summarise key aspects of these standards for installers of Hobson structural products. It is not intended to replace the use of these standards.

#### Fit-Up of Steelwork

Bolt holes shall be aligned so that bolts can be easily inserted without damage. Drifting to align holes shall not distort or enlarge the holes. Temporary "slave" bolts may be used to assist with hole alignment but shall be marked and replaced after fit-up of steelwork.

#### Tightening Pattern

Each tightening step must be completed for all bolts in a connection before progressing to the next step. To ensure equal tension in all bolts in the connection, more than one cycle of each step may be necessary.

The tightening pattern should be outlined in the fabrication specification, if none is provided then tightening shall proceed from the stiffest (most rigid) part of the connection out towards the free edges. The most rigid part of a splice connection of an I beam is typically the middle of the connection. The most rigid part of an end plate connection of an I beam is typically beside the flanges.

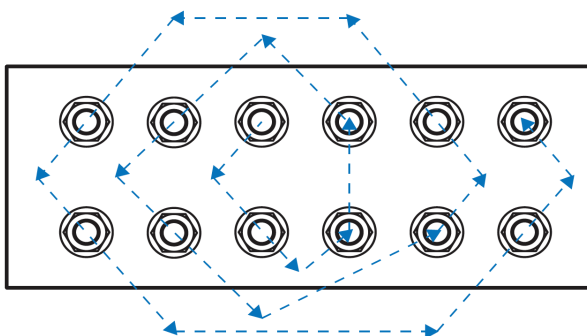

Figure 1. Sample tightening pattern

### Snug Tight (S)

Snug-tight is achieved by a few impacts of an impact wrench or by the full effort of a person using a standard podger spanner.

Ensure that the load-transmitting plies are brought into *firm contact*. Firm contact is where the plies are solidly seated against each other, but not necessarily in continuous contact.

### Gap Inspection

After snug tightening the gap between steel plies shall be less than or equal to 2mm.

If the connection is to be tensioned then the gap must be less than or equal to 1 mm. Friction connections should be inspected by an engineer prior to tensioning to ensure faying surfaces meet the requirements necessary to develop the design friction.

### Tensioning of Structural Bolts (TF/TB)

#### Minimum Bolt Tension

After tightening, all bolts in the connection shall have at least the following bolt tension.

Nominal Size	Minimum Bolt Tension (kN)
	Bolt Property Class
	8.8
M12	51
M16	95
M20	145
M22	182
M24	210
M27	275
M30	335
M33	379
M36	490

Table 2. AS 4100 Table 15.2.2.2 Minimum bolt tension

K0 structural bolts shall be tightened using either the **Part-Turn of Nut** method or using **Direct Tension Indication (DTI)** device. Torque or hydraulic/pneumatic pressure should **NEVER** be used to measure bolt tension for K0 structural assemblies.

## Part-Turn of Nut Method

After first bringing all bolts in the connection to snug tight and inspecting for any gap in the steelwork, match mark the bolt assembly. Match marks should start in the centre of the bolt end and travel radially out across the nut and onto the steelwork.

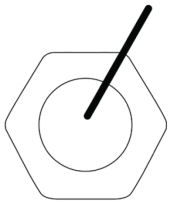

Match Making  
(Pre-tightening)

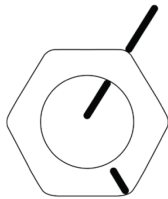

Inspection  
(Post-tightening)

Once the assembly is match-marked rotate the nut by the amount required from AS/NZS 5131 table 8.5.6.

The tolerance on rotation: for 1/2 turn or less, 30° over and nil under tolerance; for 2/3 turn or more, 45° over and nil under tolerance.

Bolt Length (L)	Disposition of outer face of bolted parts		
	Both faces normal to bolt axis	One face Normal and the other sloped	Both faces sloped
≤ 4d	1/3 Turn	1/2 Turn	2/3 Turn
4d ≤ 8d	1/2 Turn	2/3 Turn	5/6 Turn
8d ≤ 12d	2/3 Turn	5/6 Turn	1 Turn

Table 3. AS/NZS 5131 Table 8.5.6 – Nut rotation from snug-tight

## Direct Tension Indicating (DTI) Washers

### DTI Washer Assembly (DuraSquirt)

DTI washers may be placed either on nut side or the bolt head side of the connection. The DTI washer must have a structural washer bearing on the bumps. To avoid the need for an additional washer it is recommended that the DTI washer is placed on the nut side of the connection.

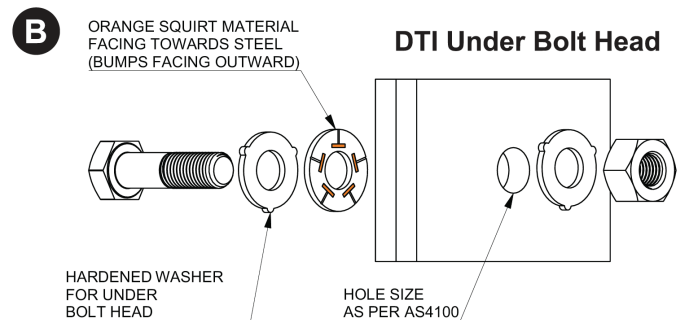
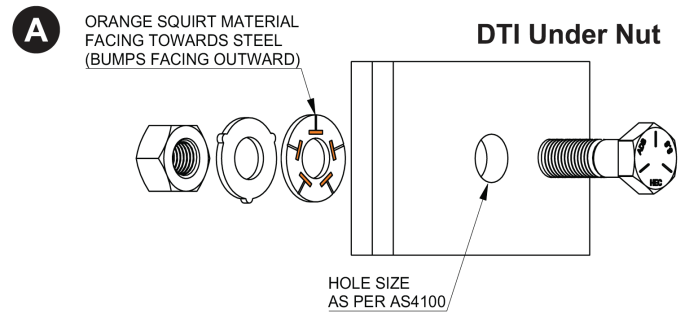

### DTI Washer Installation

After first bringing all bolts in the connection to snug tight and inspecting for any gap in the steelwork, tighten the DTI washer assemblies until you observe orange indication from all bump locations.

Nominal Size	No. of Bumps
M12	4
M16	4
M20	5
M24	5
M30	7
M36	8

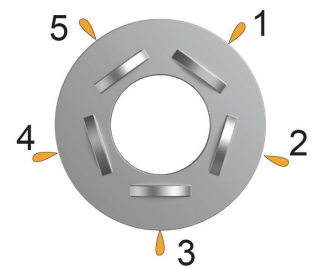

Table 4. DuraSquirt DTI bumps

Bolt Tension | Anti-Vibration | Product Reliability | Traceability



holding New Zealand together since 1989



blacksfasteners.co.nz